

RECOLLECTIONS

**Official Newsletter of the Werribee and District
Collectable Vehicle Club (Inc.)**

PO Box 841 Werribee 3030

Inc. Reg. No. A0024084P

ABN 575 840 445 12

www.wdcvc.org.au (E-Mail: - wdcvc@hotmail.com)

JANUARY 2024 EDITION



Members Rides

Tibor & Victoria's 1967 Chevrolet

**FIRST GENERAL MEETING FOR 2024 is WEDNESDAY 28th FEBRUARY (7.30pm)
PLEASE NOTE: NO MEETING IN JANUARY**

The Werribee and District Collectable Vehicle Club (Inc.)

Was formed in June 1991 to foster and advance interest in History, Restoration, Care and Preservation of Classic and Historic Motor Vehicles. It provides an avenue for sharing of information by owners of those vehicles. The Club is a not-for-profit organisation. We welcome as members all those interested in preservation of our motoring history.

Club regularly conducts events, monthly runs for its members and assists community organisations with attendance at community events, retirement homes, parades and car shows.

The Club's recently constructed Club Room caters for a range of activities such as Club gatherings, meetings and is often our starting point for runs.

Generally our members come from those who own vehicles over 25 years old, but this is not a prerequisite for membership, anyone is welcome.



HAPPY BIRTHDAY TO ALL MEMBERS HAVING A BIRTHDAY THIS MONTH

*Joan Gosney, Sam Pernice, Peter Fragioli &
Ryan Kaio*

If you would also like to receive a birthday shout out, email our editor Jenny (magoos_4@bigpond.com) advising birthday month for yourself and your better half.



Our best wishes to the following members.

- John Agosta (Snr) recovering from Stents and waiting for an operation to replace a heart valve.
- A good number of members have recently succumbed to COVID, and a few were very ill. We hope you have all now recovered back to full health.

GET WELL WISHES ALSO TO ANY CLUB MEMBER WHO MAY CURRENTLY BE FEELING POORLY



*Condolences to Brian Gosney and family on
the recent passing of his brother back home
in New Zealand.*



WDCVC Life Members

Gil Taylor (Dec)
John Agosta (Jnr)

Sandy Taylor (Dec)
Charmaine Agosta

Les Turner
Elio Massari

Ladies, would you like to get away for a few days?

Then why not join us on a

“Ladies 3 day Mid-Week Getaway” to Warrnambool

When: Monday 4th to Wednesday 6th March

Staying 2 nights at Discovery Parks Warrnambool.

**“Located by the beach, Discovery Parks - Warrnambool
features a swimming pool with spa pool.”**

Shared accommodation - fully self-contained cabins sleep between 3 - 5 ladies.

Getting there: Car pool - no more than 4 ladies in each car.

Details are still being finalised, but we expect the cost to be around \$170 per person which includes accommodation, transport and entry to Deep Blue Hot Springs.

All Meals and any other activities are your expense and not included in price.

14 places available

So many things to do and see ... just a couple ...

- ◆ **Deep Blue Hot Springs**
- ◆ **Fletcher Jones Market and Gardens**



Discover the myriad of open-air rock pools, sensory caves and cleansing waterfalls while soaking in the therapeutic waters, naturally rich in minerals and heat. at The award-winning Deep Blue Hot Springs Warrnambool. The ultimate geothermal mineral bathing Sanctuary. while soaking in the therapeutic waters, naturally rich in minerals and heat.

Fletcher Jones Market - Located in the iconic former Fletcher Jones factory, and fronted by a heritage-listed garden, the market is packed with antiques, antiquarian books, collectables, retro, vintage, a great collection of records, vintage clothing, new giftware and loads more.

With two floors to choose from and well over 60 stalls, the Market has something for everyone.

Take a stroll through the garden and enjoy the wonderful history of the Fletcher Jones clothing company.



**If you are interested in joining us, please contact Connie Mallia on
0439 619 083 by 31st January.**

Please note: a \$50 non-refundable deposit will need to be paid on booking.

Werribee & District Collectable Vehicle Club (Inc.)

Registration Number A0024084P ABN 575 840 445 12

CONTACTS for WDCVC COMMITTEE July 2023 to June 2024

Mail to P.O. Box 841 Werribee 3030

E-MAIL: wdcvc@hotmail.com

Name	E-Mail	Phone
Executive Committee		
<u>President</u> Colin Pierce (Shirley)	colin@colshirl.com	0413 884 234
<u>Vice President</u> Daniel Smith (Amanda)	Djs84@outlook.com.au	0408 328 028
<u>Secretary/Public Officer</u> Carmel Calleja (Nick)	wdcvcsecretary@gmail.com	0421 305 721
<u>Treasurer</u> Jenny Matthews (Rod)	magoos_4@bigpond.com	0422 699 361
General Committee		
Heather O'Brien	hethaob@bigpond.net.au	0411 239 446
Connie Mallia (Ronnie)	c.m.62@hotmail.com	0439 619 083
Office Bearers		
<u>Club Captain</u>		
<u>Editor & Publisher</u> Jenny Matthews (Rod)	magoos_4@bigpond.com	0422 699 361
<u>Mid-Week Run Captain</u> Les Turner (Lorraine)		9741 6657
<u>Safety Officers</u> Elio Massari (Nancy) Charlie Cook (Lyn)		9741 6103 9741 3328
<u>Club Permit Officer/s</u> Yves Schieseck (Sandra) Wayne Rodgers (Jen) Colin Pierce (Scrutineer)	breton29@aussiebroadband.com.au waynerodgers.61@gmail.com colin@colshirl.com	9749 3376 0405 380 005 0413 884 234
<u>Regalia Officer</u> Len Mallia (Carmen)	lencar6@bigpond.com.au	0412 529 801
<u>Librarian</u> Peter Kime (Patricia)	pjkime@hotmail.com	0409 798641
<u>Web & Face Book Monitor</u> Daniel Smith (Amanda)	DJS84@outlook.com.au	0408 328 028
<u>Welfare Officer</u> Rose Ravaneschi	sirbas53@hotmail.com	0412 456 892
<u>Social Secretaries</u> Connie Mallia (Ronnie)	c.m.62@hotmail.com	0439 619 083
<u>Federation Representatives</u> Colin Pierce (Shirley) Michael Galea (Linda)	colin@colshirl.com mgal6416@gmail.com	0413 884 234 0421 670 304
<u>Council Representative</u> Colin Pierce (Shirley)	colin@colshirl.com	0413 884 234
Financial Consultant- Werribee Accounting		

VICROADS CONTACTS and CLUB BANKING DETAILS

VicRoads Melbourne:

Switchboard 1800 816 727,

Club Permit Scheme (CPS): 9854 2674

Web Site: www.vicroads.vic.gov.au

W.D.C.V.C. CLUB BANKING DETAILS: (For Direct Deposits) GREAT SOUTHERN BANK: BSB# 814282 ACC# 10495827

ACC Name: Werribee & District Collectable Vehicle Club



Calendar of W.D.C.V.C's Upcoming Events



W.D.C.V.C Extends an Invitation to Members of any Registered Club to attend any run or event organized by our club.

EVENT	Date	Time	Coordinator
JANUARY			
"NO" GENERAL MEETING in January			
FIRST Casual Sunday for 2024	Sunday 28th	From 9am	John 0407 546 235
FEBRUARY			
COFFEE MORNING - VIEWS CAFÉ K Road Werribee South	Sunday 4th	10.30am	Colin 0413 884 234
Committee Meeting	Monday 5th	7:30pm	Colin 0413 884 234
TINKERS INFORMATION DAY - Revival Brake Restoration Division, 7 East Derrimut Crescent, Derrimut. BBQ Provided after Tour	Wednesday 7th	10.30am	Colin 0413 884 234
Club MID-WEEK RUN - Clifton Springs GOLF CLUB. Meet at BP S/S Geelong bound Highway, Little River. Bookings essential.	Wednesday 14th	10.30am	Les Turner 0408 014 358
Casual Sunday Meeting	Sunday 25th	From 9am	John 0407 546 235
FIRST Club General Meeting for 2024 (Club Rooms)	Wednesday 28th	7.30pm	Colin 0413 884 234
MARCH			
COFFEE MORNING - The Feasting Shed, 71 Railway Ave, Werribee.	Sunday 3rd	9.30am	Colin 0413 884 234
"Ladies 3 day Mid-Week Getaway" to Warrnambool. Visiting Deep Blue Hot Springs and Fletcher Jones Market and Gardens. If you are interested in going, please contact Connie Mallia on 0439 619 083 by 31st January. Details are still being finalised. See flyer on page 3.	Monday 4th to Wednesday 6th	TBA	Connie Mallia 0439 619 083
Committee Meeting POSTPONED due to Ladies Midweek Getaway.	TBA		Colin 0413 884 234
Club Run to Great Ocean Road Chocolatier & Ice Creamery, 1200 Great Ocean Road Bellbrae (Near Bells Beach). Meet 9am at BP S/S Little River. After Chocolate Factory, cruise to Inverleigh Hotel for Lunch. To Book, Contact Run Coordinator: Russell Thompson at jemtribe@bigpond.com or 0407 420 692.	Sunday 17th	9:00am	Russell 0407 420 692 Colin 0413 884 234
CLUB MEMBERS ONLY CAR SHOW (Trophies on offer) Location TBA	Sunday 24th	TBA	Colin 0413 884 234
General Meeting (Club Rooms)	Wednesday 27th	7.30pm	Colin 0413 884 234
"NO" Casual Sunday Meeting for March due to Easter			

The above events are in accordance with the WDCVC & Vic roads Club Permit Scheme. If you wish to use your red plate vehicle, a reminder that you will need to correctly fill in your red plate permit scheme log book and be a financial member. At the time of printing the above information was correct. The Committee may change the information at their discretion. Any changes will be published in the Newsletter / Website / Facebook. Symbols of events are Club Runs in *bold*, and all other runs organised by Vic roads or other clubs will be in normal font.



WDCVC minutes of General Meeting held: 13th December 2023

Chairman: Colin Pierce **Vice President:** Apologies

Meeting opened: 07:35pm **Meeting closed:** 8:20pm

Visitors: Nil **Speaker:** Nil

Apologies: Reno Polidano, Andrew Babbage, Mitch Jones, Ian Cameron, Elio Massari, Tony Todaro, Nick and Carmel Calleja

Minutes of previous meeting: Comments/Questions: Nil **Moved & Accepted:** 1st Charles Pace 2nd Werner Bernhardt

Minutes of Committee Meeting Held on 4th December: No report as Carmel away.

Correspondence:

- No Correspondence **IN or Out**

Treasurers August Report to: 30/11/2023 Presented by Jenny Matthews (Treasurer)

Comments/Questions: NIL .

Moved & Accepted as presented: 1st Linda Galea 2nd Vicki Miskolczi.

President's ramblings:

- Colin thanked everyone who helped make your Club Christmas Picnic and Children's Party a success. A special thank you to Connie Mallia (Club Social Secretary), Tony and Connie G, Les Turner (AKA Santa), Vicki (Mrs. Clause), Lindsay, Linda G and everyone for attending.
- Colin thanked all members who volunteered throughout the year by representing the Club by displaying their cars at community centers and old age care homes around Werribee.
- Colin thanked John Marks for running Club's Casual Sunday along with all volunteering members, John, Lindsay, Brian, The Luke family, Vicki, Connie G and Connie M, Breaden and Colin, Rose (Tea/Coffee Lady) and a especial thank you to our BBQ cooks, Mark, Heather, Linda H, Linda and Mick and anyone else that helps on the day.
- Ballarat weekend away as a Club cancelled due to members and coordinators inability to attend, this does not prevent members attending but need to make their own arrangements.

Club Coming Events Report:

CLUB Mid-Week Run in February to Clifton Springs Golf Club. Contact Les to book.

Other Runs and Events:

- Sunday January 7th Coffee Morning Little Growling Café 2 Resin Street Mambourin, time 10:30 at Café
- Sunday 14th 11:00 Picnic at Cherry Lake Altona (Off Millers Road) opposite Stirling Avenue)
- Sunday 28 Casual Sunday
- Sunday 4th February Coffee Morning 10:30am at Views Café (K Road Werribee South)
- Wednesday 7th to AAD Brake restorers in Derrimut. Let me know if you intend coming I already have a list of 14 members coming.
- Wednesday 14th Mid-Week Run to Clifton Springs Golf Club
- Sunday 25th Casual Sunday

Social secretary's report: Connie Mallia.

- Connie thanked everyone for their help at Club Picnic and Children's Party. Connie mentioned that the Face painter hired this year would not be considered for future events.

Editors report: Jenny NOT running her MARS BAR competition in December or January Newsletters.

Raffle Winner/s: Harmony White (Christmas Cake Donated by Lyn Cook), Jenny Matthews (Christmas pudding, donated by Vicki), Len Schutt, (Car Pillows donated by Vicki), David White, (Mancave Plates), Kerry White (\$50 Bunnings Voucher), Mick Galea (\$50 Voucher), Helen Taylor (\$50 Voucher), Shirley Pierce (Car Pillows donated by Vicki), Heather O'Brien (Seat), Peter (Cushions donated by Vicki).

General/New Business:

- Proposal is to not hold a General Meeting in January. This proposal put to the members and following some discussion at vote taken with majority voting to uphold the proposal. So there will be **NO General Meeting** held in January 2024.

Thanks for reading on behalf of **Club Secretary-Carmel**

CLUB COFFEE MORNING SUNDAY 7TH JANUARY TO LITTLE GROWLING CAFÉ MAMBOURIN

Club arranged a Coffee morning for first Sunday of 2024 at new location for Club called 'Little Growling Café' which is part of Mambourin Club on Black Forest Road where we remembered this whole area was paddocks only a few years ago but is now full of new housing estates.

As this was our first time visiting this Café, although word had spread it was a nice place for a Coffee, no one really knew what to expect, but we were pleasantly surprised.

Management and their staff were exceptionally friendly and no request was too much for them, and we were even invited back. Food was fresh and meals and Coffee came out hot.

Mostly chatter centred around what we all did over Christmas and New Year's Eve with many having some nice stories about family and friends coming together to celebrate the festive season.

For first outing for 2024 we all enjoyed coming together and in many cases an excuse to bring out one of our cars to blow the cobwebs away.



NAME	VEHICLE	NAME	VEHICLE
Colin and Shirley	VZ Calais	Margaret Pengelly	Modern
Lindsay Coghill	XJ6 Jaguar	Helen Taylor	
Brian Daly	1983 Ford Meteor	Paul Sammartino	1956 FJ Holden
Mick Graham	Modern	Ian Miller	SL Capri Convertible
Werner Bernhardt	Modern	John and Elisabeth	Modern
Rod and Jenny	1966 Mustang	Brian Cameron	Modern
Mick and Linda	GT Falcon	Kerry and Janet	HZ Kingswood
Charlie and Lyn	Modern	Trevor and Wassana	Modern
Alex Grixti	1973 Mustang Mach 1	Alex and Jarrod	Modern



Club Cruise and Lunch

Sunday 17th March

Location: Great Ocean Road Chocolaterie & Ice Creamery
About 80Ks (1 Hour) Cruise from Werribee.

Address: 1200 Great Ocean Road Bellbrae (Near Bells Beach).

Meet at BP Service Station Little River at 9:00am.

After Chocolate Factory we then Cruise to Inverleigh for Lunch at Inverleigh Hotel About 82Ks (1 Hour 25 mins) Drive.



To Book, Contact Run Coordinator: Russell Thompson at
jemtribe@bigpond.com or 0407 420 692.

President's Report



Dear Members.

Happy New Year to all, I'm eagerly looking forward to a great 2024 full of events, runs and meetings.

I'm a little late sending my report and already Club has held two runs and its only 15th January.

Coffee morning at Little Growling Café in Mambourin and a Picnic/BBQ at Cherry Lake Altona, we had very good attendance to both events and if this interest continues, as a Club we should have some great events.

The team are working on a number of special events for 2024 and I recommend you monitor Events page each month for what is planned.

The ladies are organising a "Ladies Only Trip" as the last couple of these were very successful. More details on page 3.

Club arranged an Information Day on Wednesday 7th February to visit Revival Auto Parts – Brake restoration specialists in Derrimut to see how brakes are restored back to refit to our older vehicles, followed by a BBQ, so far we have a good number of members interested in attending. If this works out to be something members wish to hold then more events will be planned.

A member only Car show is under planning where Club Car of the year will be chosen plus trophies handed out on the day.

Take note there is NO GENERAL MEETING being held this January.

Club's first Casual Sunday, 'Coffee and Cars' recommences on last Sunday of the month, this month it's Sunday 28th January 9:00am to 12 Noon at normal location in car park on corner of Cherry and Kelly Streets Werribee, come along, grab a coffee or Egg and Bacon Roll and check out fellow members and visitors rides.

Cheers

Col



Club Picnic/BBQ Cherry Lake (Altona) Sunday 14th January

Weather bureau got it just right for our Club Picnic/BBQ at Cherry Lake reserve.

Members were eager to meet up at a great location for a Picnic with an added bonus of it not being too far to drive for a Club gathering.

Car parking was not far from our site and during day many moved their cars once a spot was vacated closer to our area. One issue was council obviously not back yet from their holidays, as grass was very long preventing many of our games like Bocce and other ball games being played.

Early arrivals were soon roped in to erect Club Gazebo's for shade and cover "if" it happened to rain although rain wasn't in forecast.

Other members soon began arriving and quickly began pegging out their place to setup picnic tables and chairs with an abundance of food soon filling tables.

Dennis and Josie arrived via "**Shank's Pony**" (Walked. For those who may not understand saying) to attend a gathering of fellow members so it does show how much our members like getting together.

After chewing the fat and exchanging latest gossip around tables for an hour so and before we filled our bellies with luscious variety of snacks on offer we fired up Club's BBQ which heralded commencement of lunch time.

A number of members were soon cooking Steaks, Chicken, Hamburgers and good old Snags with smells wafting across causing those who brought full picnic hampers to begin preparing their plates or sandwiches.

Chatter abated for a short time while we enjoyed our meals.

After people's meals settled in their tummies some games that we were able to play came out with Horse Shoe Throwing and Bean Bag Tossing being main games.

Colin Harris soon showed up his talent for Horse Shoe Throwing with a few ringers, Pat Kime and Janet White showed their expertise with the Bean Bag Toss game.

Time slipped away too fast and unfortunately it was soon time to pack up our stuff and decamp the area.

Some members may have found on arriving home, next time it might be more prudent to wear a hat, as UV's were a little higher than temperature suggested.

One member with initials of **R.M.** (and no, not Rod) might take heed and place his Club Car on Battery Charge a day or so before an event to prevent embarrassment of requiring a jump start of his lovey Holden Monaro at the end of the day.

Thank you to Tony for providing jump leads and a car to get his car started.

Members in attendance.

Colin Pierce	1984 Statesman Deville	John Agosta (Snr)	Pontiac Tempest
Lindsay Coghill	1983 VC Commodore	Reno Polidano	1971 GT Falcon
Peter and Pat	190E Mercedes Benz	Gavin and Peta	FC Holden
Rob and Annette	BMW	Alf Schembri	1970 XW Fairmont
Kerry and Janet	HX Holden	Colin Harris	1934 Tudor
Barry and Maria	Modern	Breaden Harris	Chevrolet Nova
John and Elizabeth	1949 Mercury Ute	Kerry and Lorraine	Modern
Rod and Jenny	95 VS Statesman	Tony and Connie	Modern
Rose Ravaneschi		Des Howlett	Thunderbird
Wayne and Jen	204Z Datsun	Daniel, Amanda and Family	Nissan Pintara
Ronnie and Connie	Monaro	Dom Campos	Yamaha FZR950
Len and Carmen	VK Commodore	Ray Hill	Suzuki 959KH
Dennis and Josie	Shank's Pony	Shawn Van Roosmalen	Modern





Radiator Cap Art!

There are lots of things to like and admire in more modern cars. Their comfort, their safety, their reliability, but one simple feature of many old cars now is the magnificence and artistry of their hand-crafted design. On many, nowhere is this more obvious than in the magnificence of the humble radiator cap. Here are a few pictures that caught my eye at numerous car events over recent years.

A combination of design, beauty and function. Enjoy some tiny pieces of art.

Regards to all, Brett and Julia



THE MAN WHO INVENTED CRUISE CONTROL

Thanks to Allan and Jim from Historical Vehicles Museum NSW

In many lists of little-known automotive historical facts is a tidbit about the engineer who invented cruise control: he was actually blind. Yeah, that seems pretty incredible, but that's where the info about Ralph R Teetor begins and ends for most.



Ralph R Teetor – Smithsonian

That's sad, because the life Teetor lived was inspirational and rich, as he left an indelible mark on the automotive industry that extended far beyond just the creation of cruise control.

Born in Hagerstown, Indiana, USA in 1890, Ralph Teetor wasn't blind at birth. He spent part of his childhood in Victorian rural Indiana, with the full use of all his senses. However, an accident with a knife at the age of five left him completely blind.

His deeply religious parents didn't allow Ralph to feel sorry for himself: an attitude he adopted himself. Pulling himself up by his bootstraps, the boy learned to do what everyone else who could see did, including attending college. There was no shortage of doubters, although they were quickly won over once they saw him in action.

From a young age, Ralph had an intense interest in the work his father and uncles performed as they created maintenance cars for the railroads. He learned to work lathes, grinders and other dangerous machines in the shop, without serious injury. In fact, after a while many of the men remarked how proficient the blind boy was with their tools of trade.

Ralph further proved his wherewithal in college, which he completed with the help of a cousin. However, life took him back to the family business, which had transitioned to making components for automobiles. Because the business started to focus mainly on piston rings, the name was changed to Perfect Circle – a brand you might recognise.

Just by listening to an engine, Ralph Teetor could correctly diagnose a mechanical problem. He was famous for this, resulting in his working with several people in the automotive industry to diagnose issues, including motorsport teams. You could say he was a *car whisperer* of sorts.

Of course, his most famous contribution to the automotive industry was the invention of cruise control.

In the USA, fuel and tyre rationing during WWII was enforced by a national speed limit of 35mph that originally got him thinking of how to help people maintain a constant speed over long distances. Also, while riding as a passenger in a car driven by his patent attorney, who kept speeding up and slowing down every time he talked, Ralph realised a device that could regulate speed could improve road safety.

Having been a pioneer of automatic transmission, Teetor was already experienced with vehicle mechanisms, so he set about designing a solution to the problem.



Ralph Teetor (right), cruise control in hand, with William Prossner, president of Perfect Circle, in 1957 – Automotive Hall of Fame

The result was a system that calculated ground speed based on the rotations of the vehicle's driveshaft and used a bi-directional screw-drive electric motor to vary throttle position as needed. Once the vehicle achieved the selected speed, a governor overcame spring tension to actuate a vacuum-driven piston, which in turn pushed against the accelerator pedal.

On August 11, 1948, Teetor filed a patent application for a 'speed control device for resisting operation of the accelerator'. That patent was granted on August 22, 1950 and cruise control as we know it was born.

In the early days, the 'Speedostat' (Ralph hated the name 'cruise control' suggested later by Cadillac) featured a dashboard-mounted speed selector.

Aug. 22, 1950

R. R. TEETOR
SPEED CONTROL DEVICE FOR RESISTING
OPERATION OF THE ACCELERATOR

2,519,859

Filed Aug. 11, 1948

2 Sheets-Sheet 1

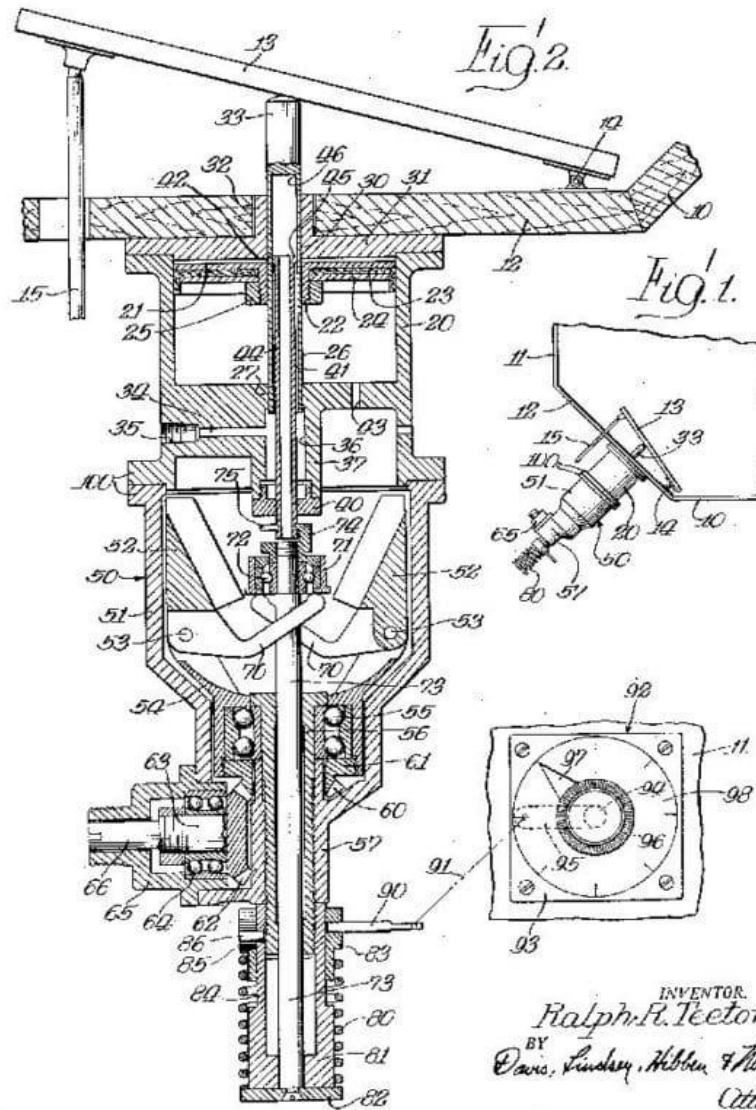

INVENTOR
Ralph R. Teetor
 BY
David L. Lindsey, Hibben & Hooper
 Attys.

In the early days, the 'Speedostat' (Ralph hated the name 'cruise control' suggested later by Cadillac) featured a dashboard-mounted speed selector.

Although the patent for this amazing invention was filed in 1948, it wasn't until the oil crisis of the 1970s that it really caught on. With a national speed limit put in place to help conserve fuel and law enforcement vigorously enforcing it, people clamoured for the device that would keep them out of trouble.

Modern electronically-actuated cruise control systems began to emerge in the 1990s, with manufacturers incorporating more advanced digital technology into the design. Other systems such as LiDAR, radar, sonar and camera-based solutions were soon added, increasing the car's ability to sense oncoming traffic, which in turn helped the vehicle to determine speed and avoid potential accidents.

Many other patents were filed by Ralph R Teetor, including one for a hydraulic automatic transmission; an improved piston for controlling heat expansion; a mechanism for dynamically balancing steam turbines in US Navy ships; a pistol-grip fishing rod handle; an easier-to-use doorknob; a better lawn mower; an easier-to-use door lock and a suitcase in which to fit more clothes without wrinkling them.

His daughter said he was always tinkering in the basement at night, with the lights off, as his mind worked on all kinds of problems. The man had an unceasing desire to improve the quality of life for everyone around him, which he did.

Throughout his life, Ralph Teetor counselled many other blind people, including war veterans who lost their sight in service to their country. He always told them to not feel sorry for themselves and to work smart as well as hard, that in so doing they could accomplish great things in their life.

The man absolutely practiced what he preached, as he didn't let his lack of sight hold him back in the least.

Ralph Teetor died in 1982 and, six years later, was posthumously inducted into the Automotive Hall of Fame in Dearborn, Michigan, for his numerous contributions to the automotive industry.

History of the Redex Australia Trial



While F1 and the WRC rule supreme in the world of motorsport in the 21st century, over Seventy years ago a much longer, and in our opinion more exciting, type of race captured the imagination of racing fans across the globe — the Redex Australia Trial.

Unlike any other race before or since, the Redex Trial was a special rally raid which saw over two hundred amateur and pro drivers circumnavigate Australia in a collection of cars, the majority of which were nowhere near appropriate enough for the tough conditions. Sponsored by Redex for the first three years, the event was later dubbed the “Redex Reliability Trial” in homage to our products, which were thought to considerably improve the reliability and performance of the competing cars.

The first Redex Reliability Trial was held in 1953, at a time when the majority of Australia’s roads either didn’t exist or were in a poor state of repair.

Even the Melbourne to Sydney stint, which is considered a fairly easy drive today, was hard going for the drivers — with dusty tracks serving as roads in place of modern motorways.



This tough terrain, coupled with the unsuitability of the cars themselves, was what generated such interest in the race, both with the fans and the drivers themselves. At the time, the idea of driving the length and breadth of Australia in an average motorcar was simply unheard of; there were few motels, and fuel stations were located some 1,000km apart in some regions, making for a logistical nightmare for organisers. Thankfully, Shell came to the rescue, placing hundreds of petrol dumps along the 5,000km route between Townsville and Adelaide. Despite the scale and significance of the race, the rules were very simple. Drivers weren't allowed to make any performance-enhancing modifications to their cars, except to add auxiliary fuel tanks and comfier seats. They would lose one point for every minute late to enter a control point, as well as a further 100 points for disobeying a direction from race adjudicators. If a driver had to swap a part at any point during the race, they would also have 500 points deducted from their overall score.

As you'd expect from such a pioneering event, the Redex Trial attracted many of Australia and the world's greatest drivers, including Ken Tubman, Stan Jones, Jack Davey and Jack Murray. Come race day of the first trial (30th August '53), a total of 187 racers set forth from Sydney on the 6,500-mile drive, with over 150,000 Sydney residents coming out to wave the drivers off on their epic trip.



Having accrued the best overall points tally, Ken Tubman was hailed the winner of original 1953 Redex Reliability Trial alongside co-driver John Marshall. The duo drove a '53 Peugeot 203, something which proved significant for the modest French car manufacturer, who experienced a surge in car sales following Tubman's win down under. To survive the mammoth route, which passed through some of Australia's most unforgiving terrain, drivers were required to carry additional fuel drums, sand mats, shovels and picks, as well as enough food and water to go the distance between each checkpoint.

While the Redex Reliability Trial no longer exists, our products still help you to keep driving. To find out more about how our products can help your engine and fuel economy,

Source: Christensen Collection, City Libraries.

5 Random Facts about CARS in the 1800's

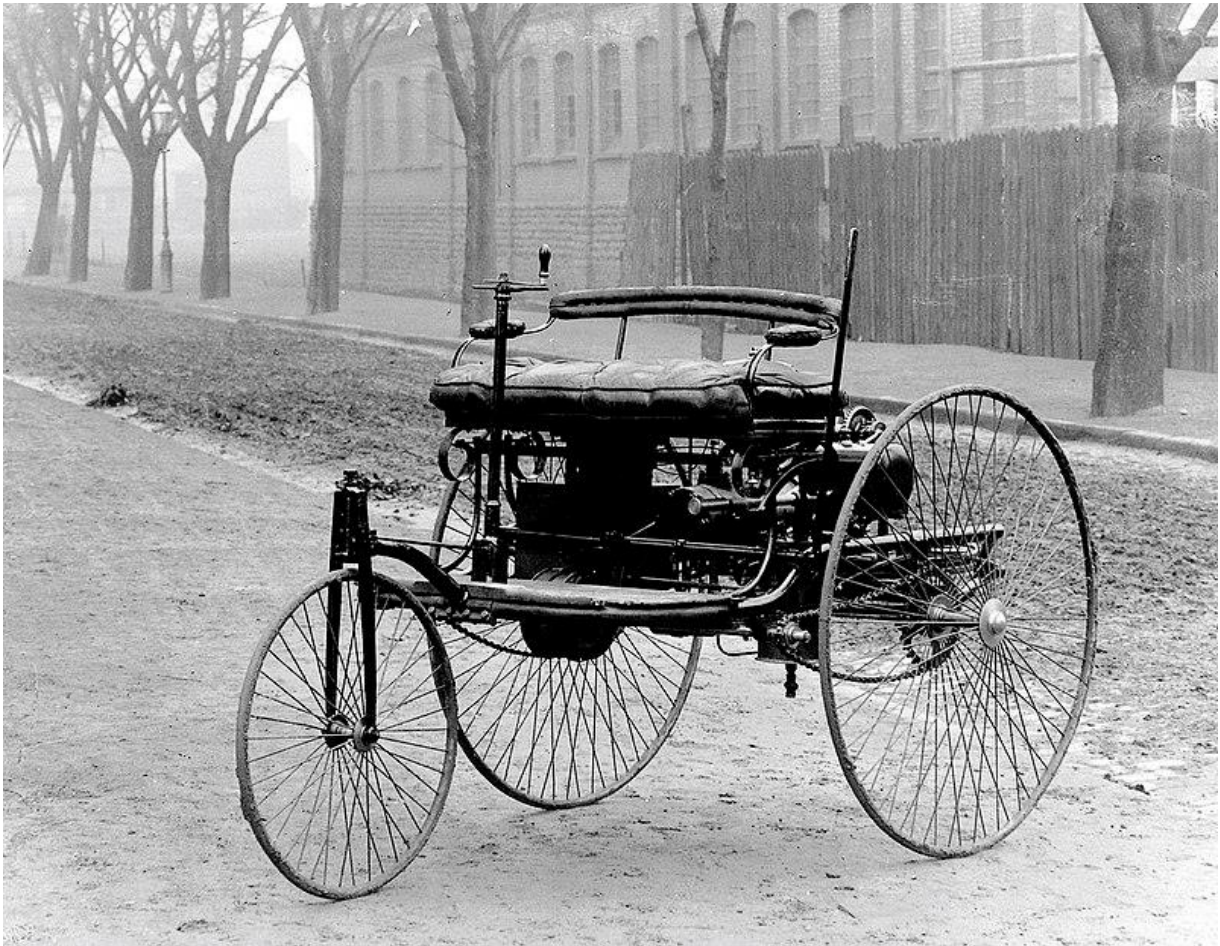

1. The First Gasoline-Powered Car Was Built in 1885

The first gasoline-powered car was built in 1885 by **German inventor Karl Benz**. His invention had a four-stroke engine that produced 0.75 horsepower and could reach a top speed of 16 km/h (10 mph). It's pictured above.

2. The First Road Trip Was in 1888

On that note, in 1888, Bertha Benz, wife of automobile inventor Karl Benz, took the first road trip in history with her two sons. They travelled from Mannheim to Pforzheim in Germany, covering a distance of 106 km (66 miles). This trip was significant because it proved that automobiles were practical for long-distance travel.

First electric car?

3. The First Electric Car May Have Been Built as Early as 1832

Scottish inventor Robert Anderson built a motorized carriage sometime between 1832 and 1839 that used galvanic cells (battery) for power. At the time, the batteries could not be recharged, so the vehicle was more of a one trick pony.

4. The First Car Accident in the US Occurred in 1891

Believe it or not, the first recorded car accident took place in **1891 in Ohio City, Ohio**. **James Lambert**, the driver of the vehicle, hit a tree root and lost control of his car, crashing it into a hitching post. Fortunately, he only suffered minor injuries, and the car was only slightly damaged. In Europe, the first death caused by an auto accident happened in 1869.

5. The First Seat Belts Were Invented in the 1800s

The first seat belts were invented in the late 1800s for horse and buggies. They were not used much in automobiles until the 1960s following the invention of the three-point seat belt. Safety laws soon came into play leading automakers to implement them in their vehicles.

There ya go, five facts about cars in the 1800s.



WDCVC REGALIA

2024



Club Polo \$30



Club Vest \$45



Summer Shirt \$50



Club Cap \$12



Winter Jacket \$55



Club Beanie \$12



Metal Grille Badge \$40



Small Hat Badge \$5

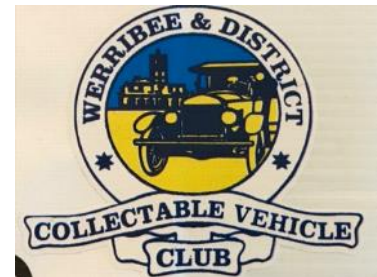

Vehicle Window Decal \$1



Windscreen Banner with Club Logo: 1800mm Long, 100mm Wide. \$13 or two for \$25

Club name badges are just \$10 and you are asked to wear them to all club events.

Payment is required in full for regalia items needing to be ordered before order will be placed with our supplier.

Len Mallia is at General Meetings to assist you. You can also call Len direct to order regalia on 0412 529 801 or email at lencar6@bigpond.com.au

OUR SPONSORS

*Bakers
Delight*

MANOR LAKES

OUR SPONSORS

REG'S RADIATORS

33 YEARS EXPERIENCE IN ALL REPAIRS

We do Cars, Trucks, Hot Rods, Classic Cars, All Car Heaters, Fuel Tanks, Fork Lifts, Change-Over Water Pumps, Anything Industrial.

MOBILE - WE CAN COME TO YOU!!!

Now Equipped with a Mobile Van for all your On-Site repair work, or in our workshop 24 Hours - 7 days a week on call.

Ph: 8742 7281

Mob: 0417 147 650

5 Yrs. Guaranteed - Conditions Apply

Factory 6, 184-190 Old Geelong Rd, Hoppers Crossing 3029

Do you know a business that would like to advertise in

RECOLLECTIONS

The Werribee and District Collectable Vehicle Club monthly newsletter?

Please speak to Colin

OUR SUNBURNT COUNTRY



AUSTRALIAN MADE HOME AND GARDEN METAL
DESIGNS THAT BRING THE OUTBACK TO YOU



CONTACT

Address: Factory 1/3 Hammer Ct,
Hoppers Crossing , VIC 3029

Phone: 0472 639 673
Website: oursunburntcountry.com



**Member Discount is available when you use our sponsors
Please remember to show your membership card to redeem discounts**



Donna Chenoweth

Senior Store Manager

Repco Hoppers Crossing & Altona

174 -182 Old Geelong Road

Hoppers Crossing VIC 3029

Tel: 03 9749 5350

Mob: 0411 431 643

Fax: 03 9749 6958

Email: hopperscrossing274@repco.com.au



OUR SPONSORS



WERRIBEE AUTO PARTS

Hi-Tec Oils AUSTRALIAN MADE & OWNED

\$30

PREMIER LITE 10W/30 ADVANCED PETROL ENGINE OIL

PREMIER 15W/40 ADVANCED PETROL ENGINE OIL

PREMIER 20W/50 ADVANCED PETROL ENGINE OIL

HI-TEC PREMIER MINERAL OIL 5 LITRE

WHILE STOCKS LAST - OFFER VALID JANUARY 2024 - NO FURTHER DISCOUNTS APPLY

PENRITE

ENGINE STOP LEAK

ENGINE STOP SMOKE

\$15 each

TRICO VISION

WINDSCREEN WASHER ADDITIVE

MADE IN AUSTRALIA

\$5.00

Hi-Tec Oils AUSTRALIAN MADE & OWNED

2-STROKE OIL 1 LITRE

\$10

Commonwealth

Meguiar's

MEGUIAR'S PERFECT CLARITY GLASS CLEANER

\$20

NULON

\$15

NULON

Pro-Strength

MULTI-PURPOSE LANOLIN LUBRICANT

NATURAL, WATERPROOF LUBRICANT

Penetrates & preserves surfaces
Long-term protection
Provides anti-seize & anti-friction properties



No further discounts apply
Quoted prices including GST
While stocks last
Ends January 2024

9734 1540
4 Quarbing Street Werribee

OUR SPONSORS

Hoists for every space

Freecall 1800 88 33 50

Request a quote today

- Our hoists are design registered with worksafe
- Engineer certification & warranty
- Third party tested for strength & integrity
- Complies with Australian standards



4 POST PARKING HOIST
TL3.6PH-S 3.6 TON/3600 KG CAPACITY

Double your parking space

- Hydraulic oil & steel jack/tool tray
- Caster kit with polyurethane wheels
- Four plastic oil drip trays
- 240V includes 15 amp plug for ease of installation



2 POST BASEPLATE
TL4.0BP 4 TON/4000 KG CAPACITY

Designed for low ceiling clearance

- Hydraulic oil
- Anchor bolts
- 8 piece pad adapter set
- Available in single or three phase power



2 POST CLEAR FLOOR
TL4.00HDI 4 TON/4000 KG CAPACITY

Overhead clear floor

- Hydraulic oil
- Anchor bolts
- 8 piece pad adapter set
- Asymmetric arms
- Available in single or three phase power



CAR ROTISSERIE
TL1.3ROT 1.3 TON/1300 KG CAPACITY

Full 360° rotation

- Heavy duty construction
- Adjustable width, height & centring
- Includes 5 polyurethane swivel caster wheels
- Powder coat finish



MID RISE SCISSOR LIFT
EE-MR35 3.5 TON/3500 KG CAPACITY

Mobile or fixed mount design

- Ideal for tyre services, detailers, sign writers and limited work spaces
- Electric safety locking system
- Height limit switch
- Durable cylinders with anti-surge valves



COMPACT SCISSOR LIFT
EE-TS6600 2.7 TON/2700 KG CAPACITY

Easy to move design

- Manual safety lock release
- Easy to move
- The dual cylinder structure ensures stable raising and lowering
- Ideal for limited work spaces

Products and colours may vary from pictures shown. Errors and omissions excepted.



View our complete range at www.tufflift.com.au

Freecall 1800 88 33 50

46 Saintly Drive, Truganina VIC 3029



OUR SPONSORS



Shop 4, 428 Old Geelong Road
Hoppers Crossing

 **8360 3818**

Come instore and see Andrew Stubbs
and mention you're a member of the club and receive 10% off RRP

RACV Emergency Roadside Assistance

**We're everywhere our
members need us.**



To find out more visit racv.com.au,
an RACV shop or call 13 RACV.

Limitations and exclusions apply.

